



# Towards A Federated African Networking and Distributed Systems Research Testbed

UbuntuNet 2024

**Innocent Ndubuisi-Obi Jr**

Paul G. Allen School of Computer Science and Engineering

University of Washington

## Research Team.



**Innocent Ndubuisi-Obi Jr**  
University of Washington



**Alex Mwotil**  
Makerere University



**Kurtis Heimerl**  
University of Washington



**Engineer Bainomugisha**  
Makerere University

What is your **theory of the status quo**?

## Theory #1: The Internet is Evolving.

DOI:10.1145/3226588

**A new model for describing the Internet reflects today's reality and the future's needs.**

BY PAMELA ZAVE AND JENNIFER REXFORD

# The Compositional Architecture of the Internet

*Evolution toward a better Internet:* In response to the weaknesses of the current Internet, many researchers have investigated “future Internet architectures” based on new technology and “clean slate” approaches.<sup>2,20,21,25</sup> These architectures are not compatible enough to merge into one network design. Even if they were, it is debatable whether they could satisfy the demands for specialized services and localized cost/performance trade-offs that have already created so much complexity. A study of compositional principles and compositional reasoning might be the key to finding the simplest Internet architecture that can satisfy extremely diverse requirements.

### >> key insights

- **For the past 25 years, the Internet has been evolving to meet new challenges by composition with new networks that were unanticipated by the original architecture. New networks make alternative trade-offs that are not compatible with the general-purpose Internet design, or maintain alternative views of network structure.**

# Theory #2: Africa's Internet Resilience is Poor.

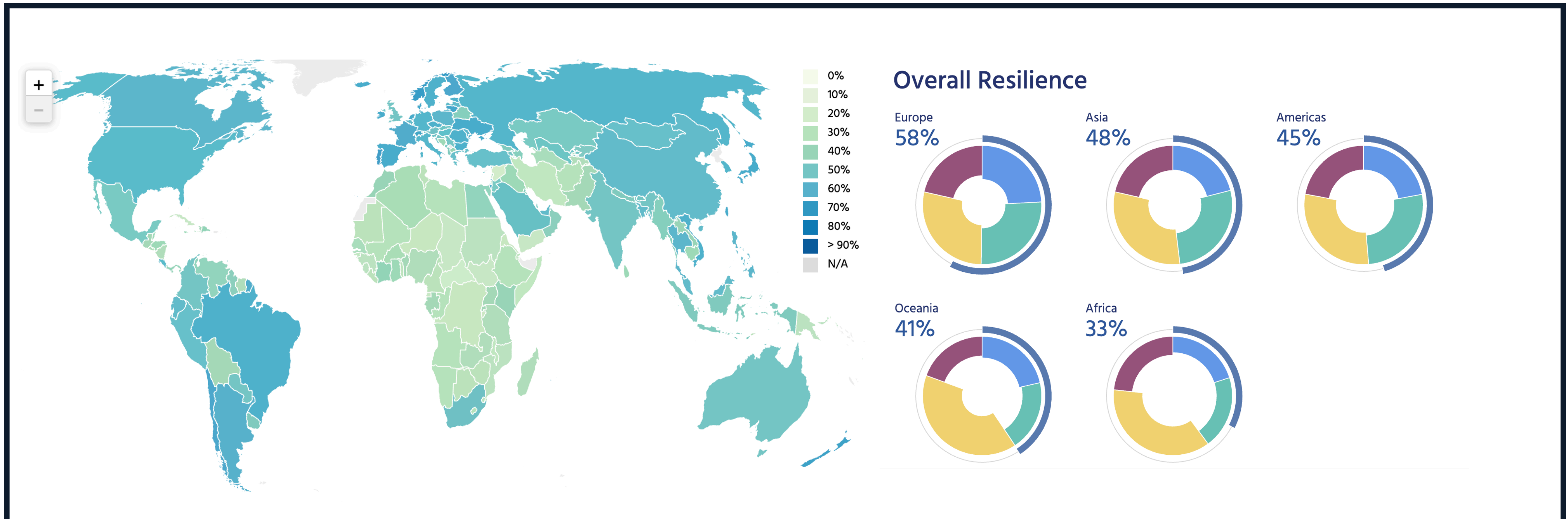

## Theory #3: We are unprepared for AI/ML Workloads

### Science

#### AI in Africa: Basics Over Buzz

ROSE M. MUTISO

### Can we afford tomorrow's AI workloads?

In principle, the cloud offers more scalable and affordable access to supercomputing power and state-of-the-art AI tools to users across the globe. However, affordability matters hugely to African users, putting cloud computing out of reach for many. Some free resources are available, such as Google's [Colab](#) and Amazon's [Sagemaker](#), but they are insufficient for computationally intensive problems. One of my Kenya-based mentees was quoted \$10,000 a month by one of the major cloud service providers to access the computing resources she needs to complete her PhD research, which is using ML and a combination of satellite and ground station data to improve the predictive performance of mainstream solar radiation models in the East African region. We are now scrambling to procure her a \$2000 higher-performance gaming laptop, which is still prohibitively expensive in her context, together with a mix of careful programming and strategic use of the limited allocations from free cloud computing platforms to string together a workable alternative. This is just one example of the hoops African AI aspirants must jump through to get a foothold in the space because of the limited access to the underlying digital infrastructure, from basic broadband internet connections to the cloud.

# Theory #4: We know the Edge, but are losing our edge.

... because our head is in the **Clouds**

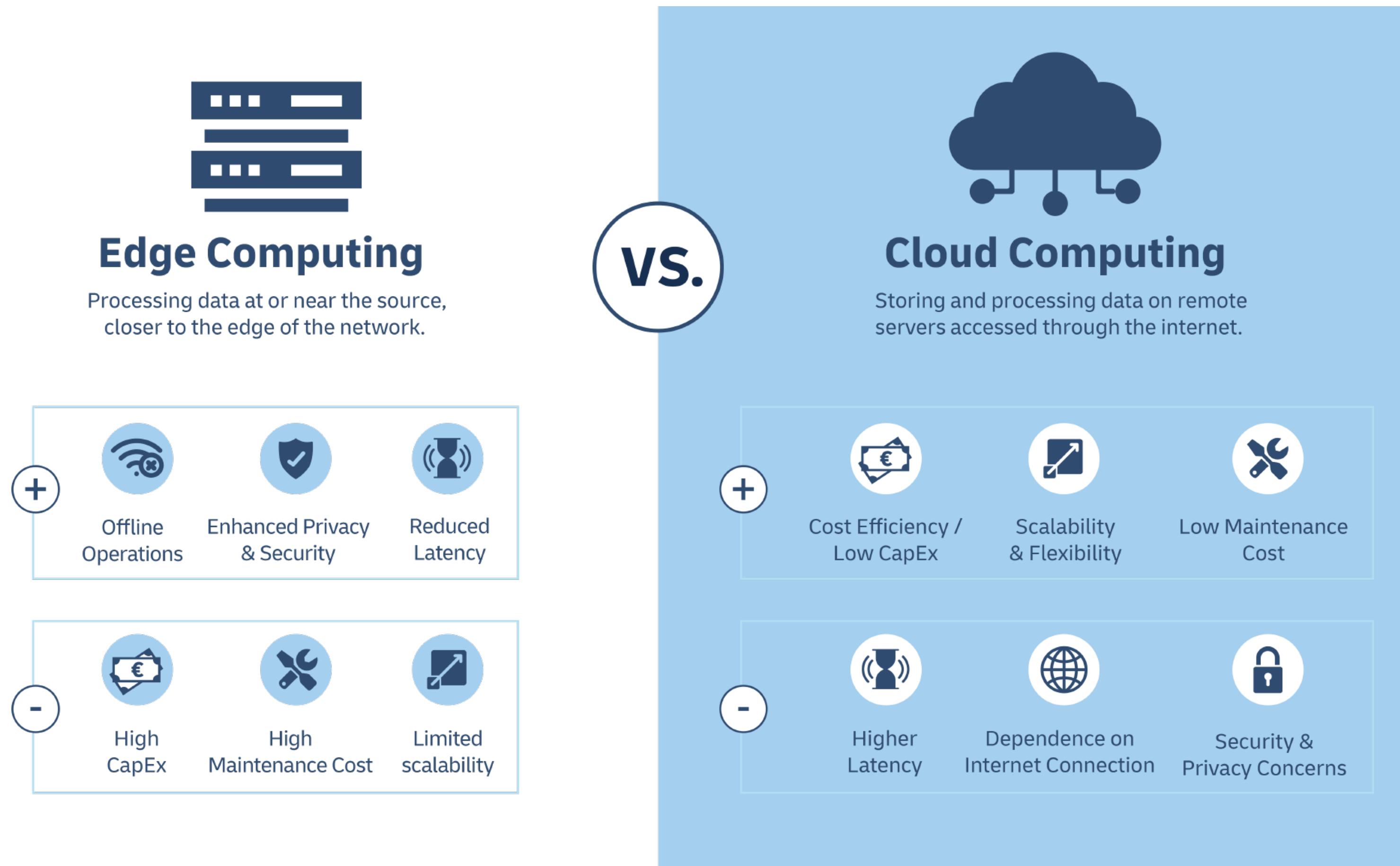



# What is this? Wrong Answers Only

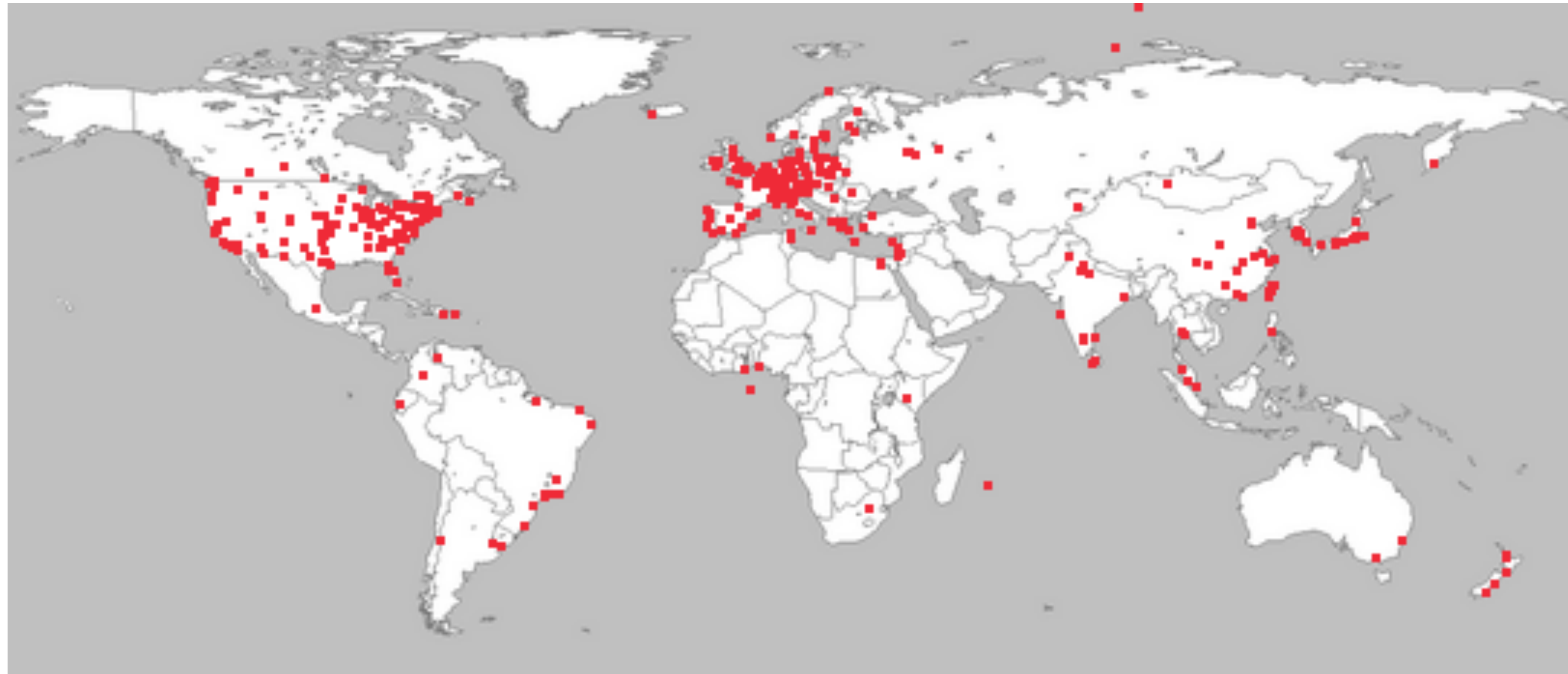

# We measure what “counts”

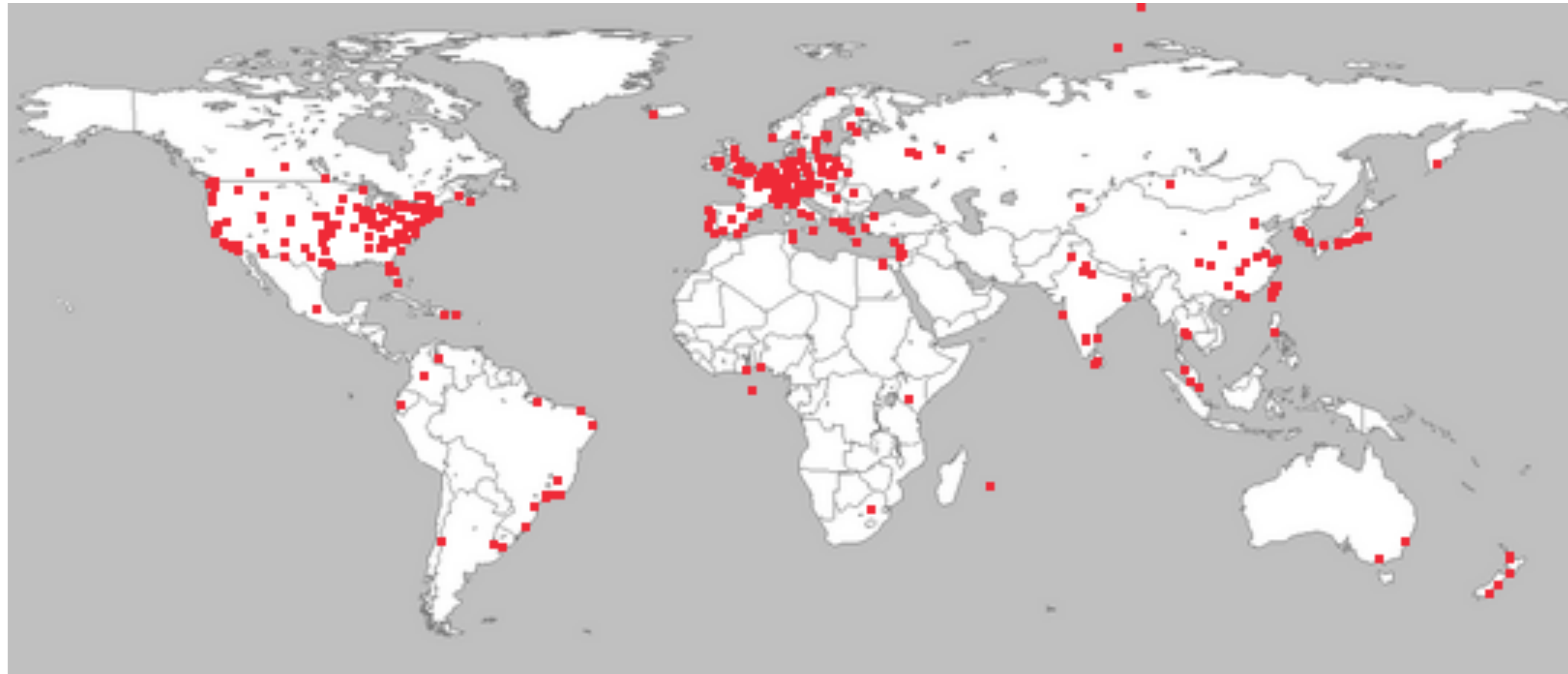

**PlanetLab**

# What about existing platforms and testbeds?

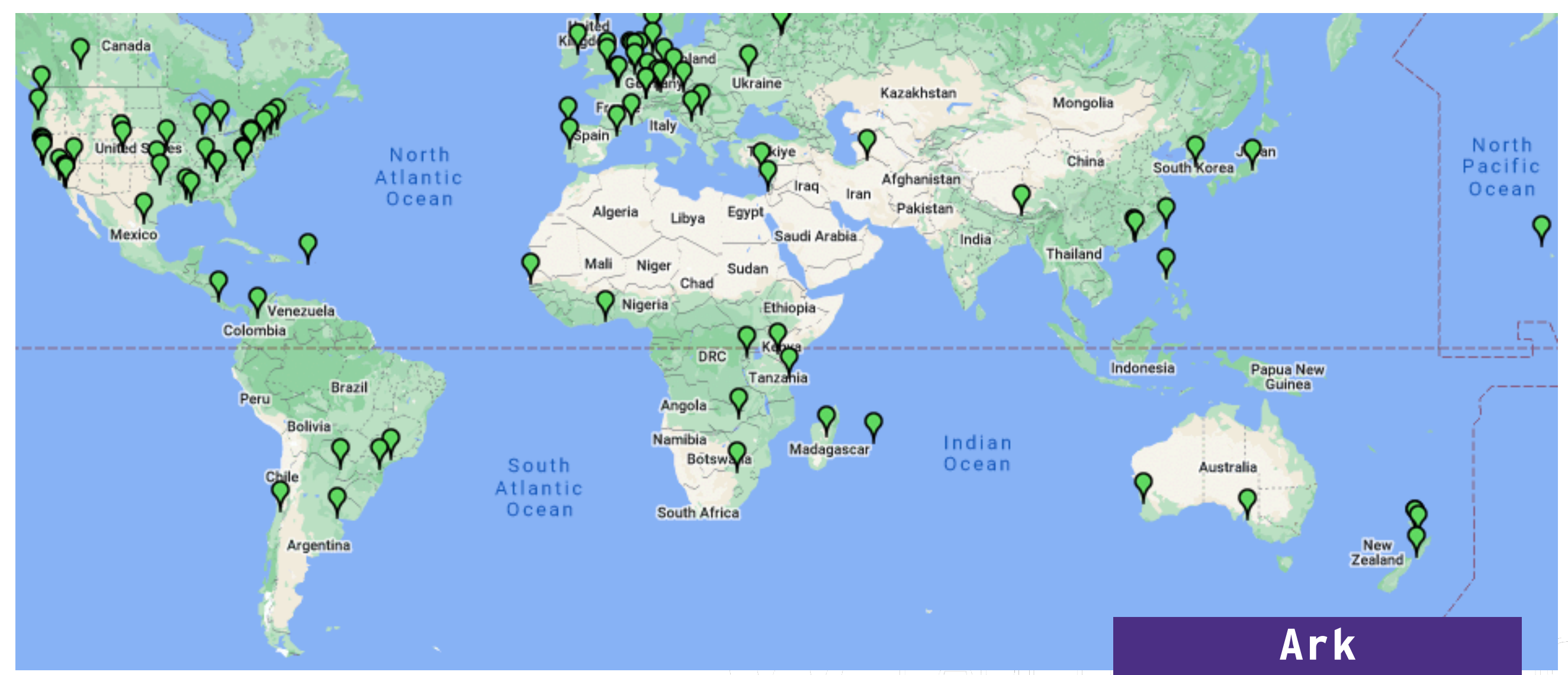
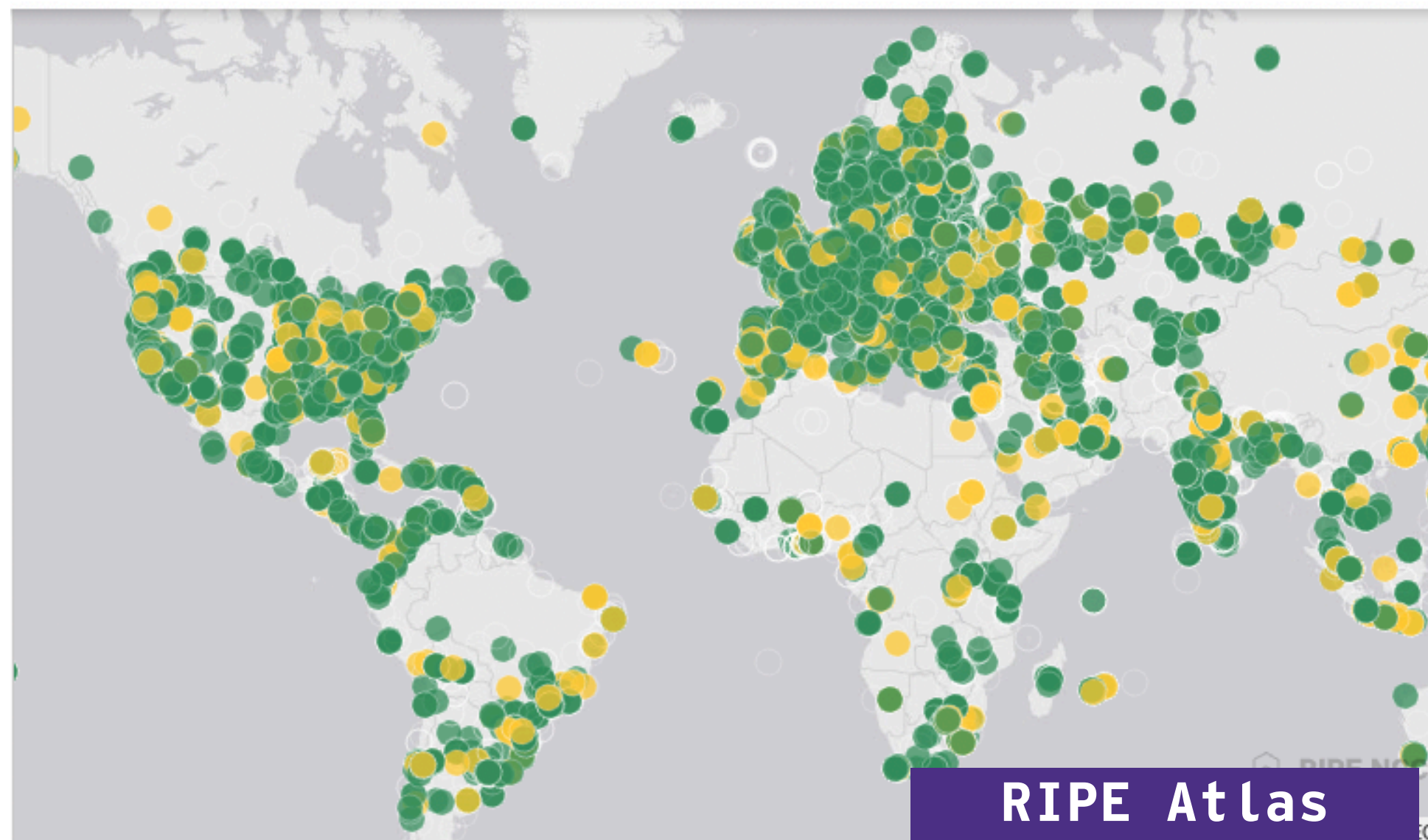
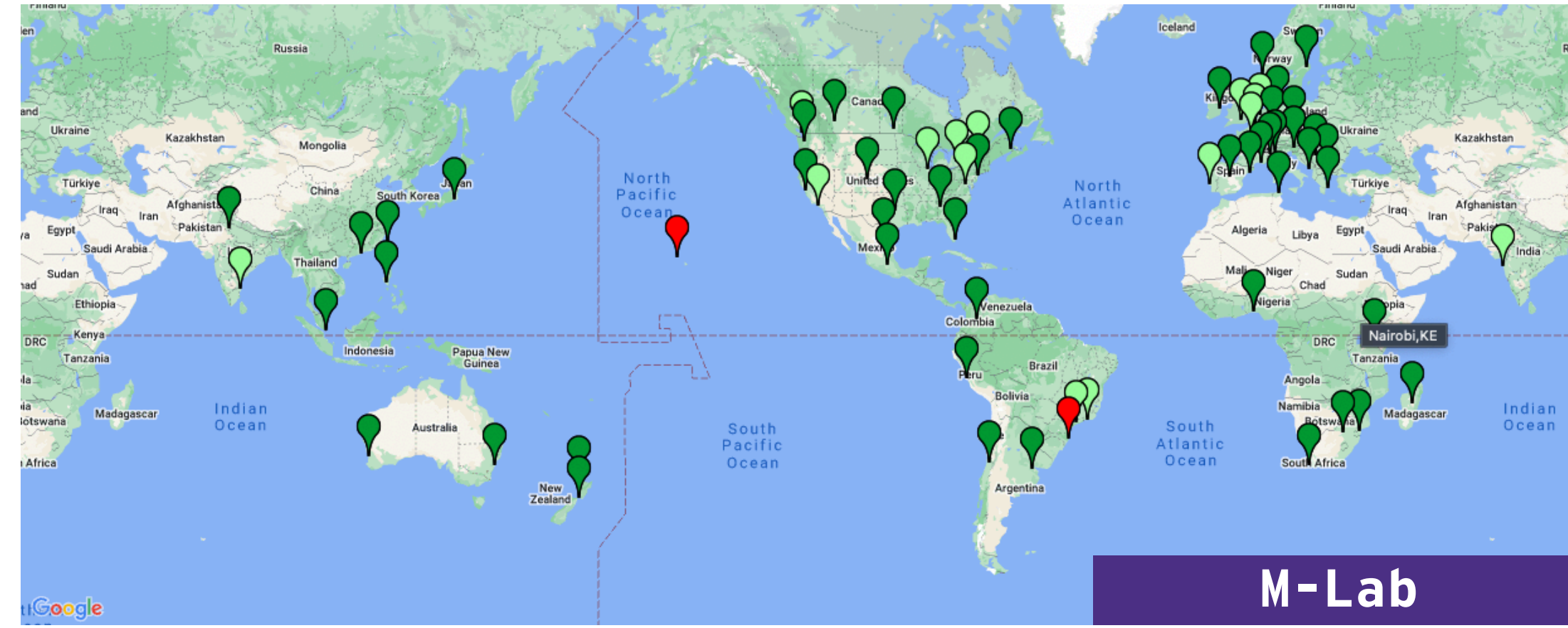
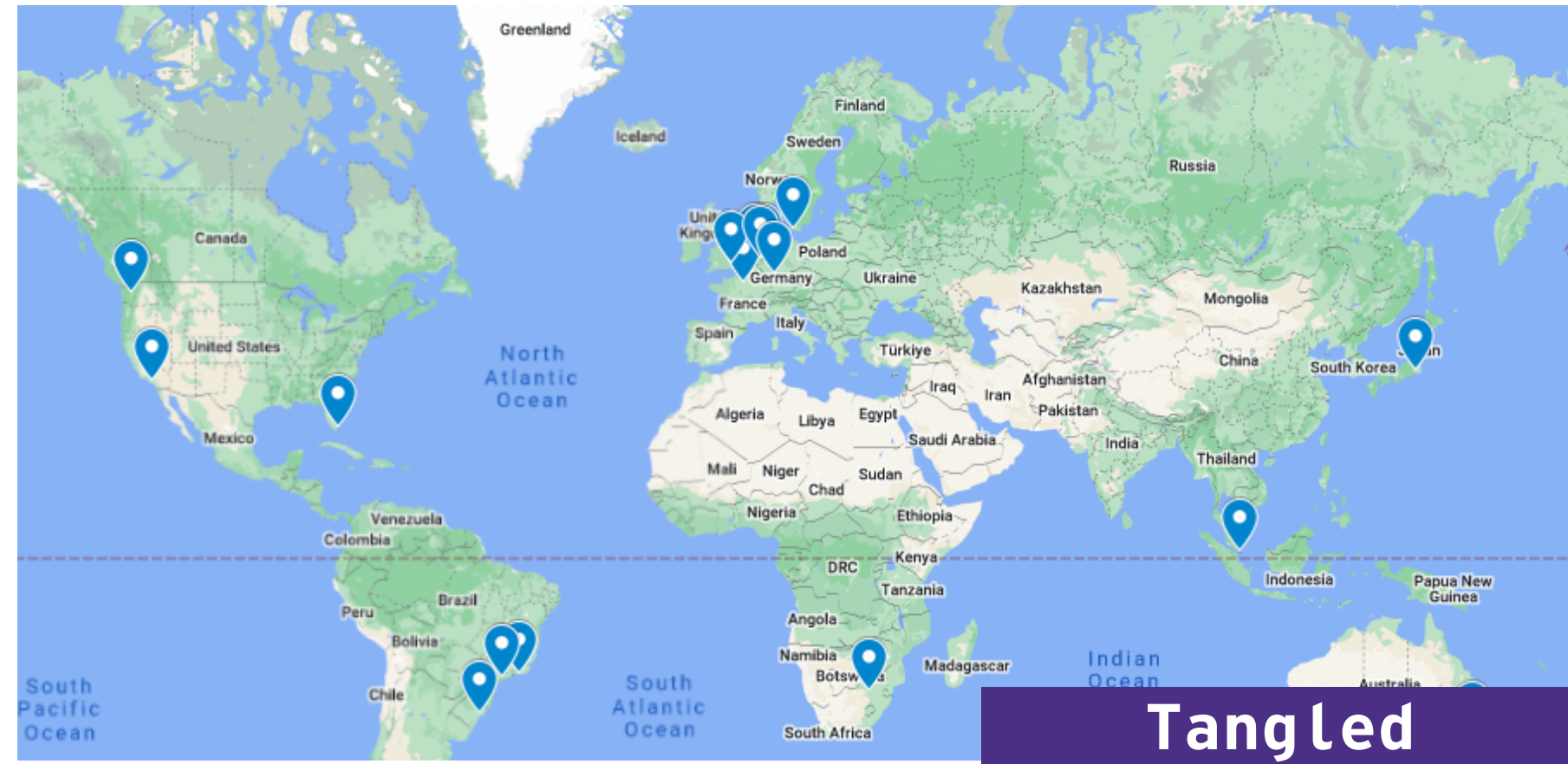

# What about existing platforms and testbeds?

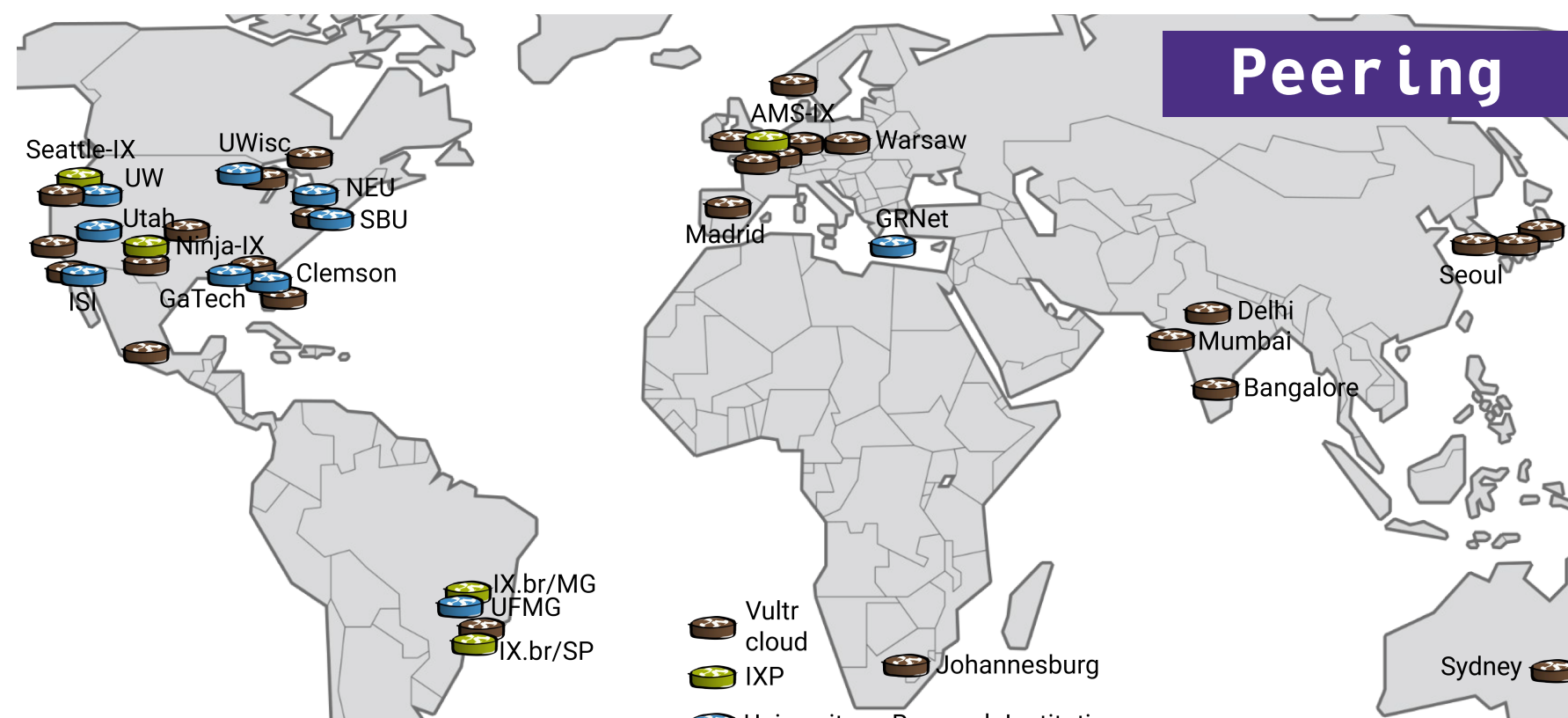
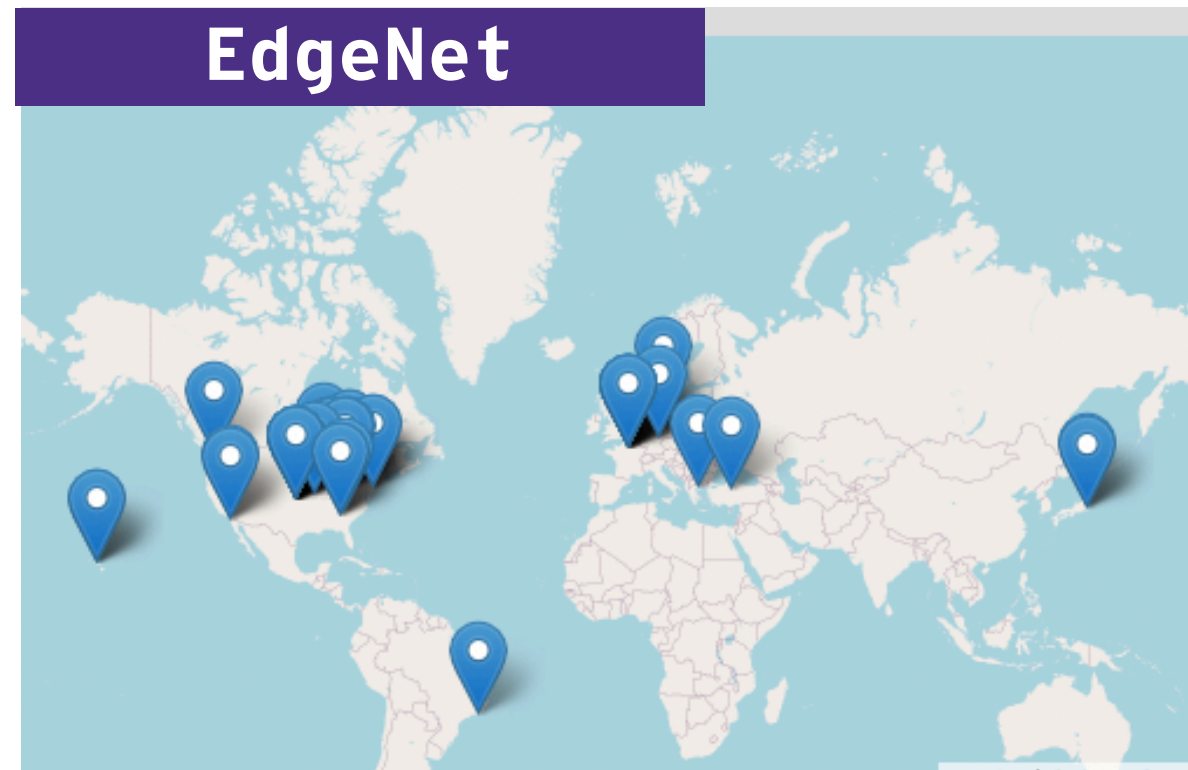

# Problem

We need to empower our researchers and innovators with the tools they need to innovate for our Internet.

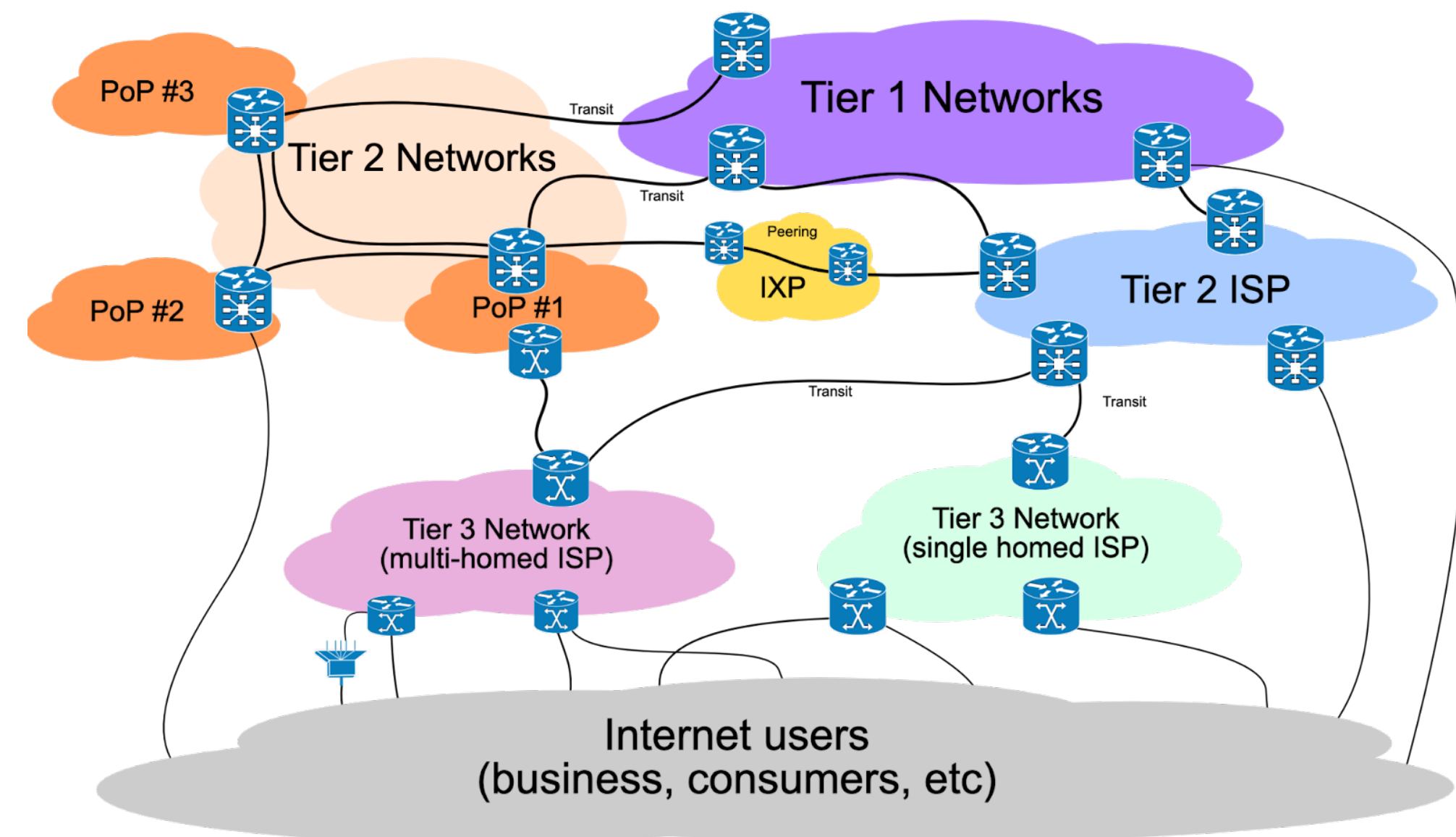
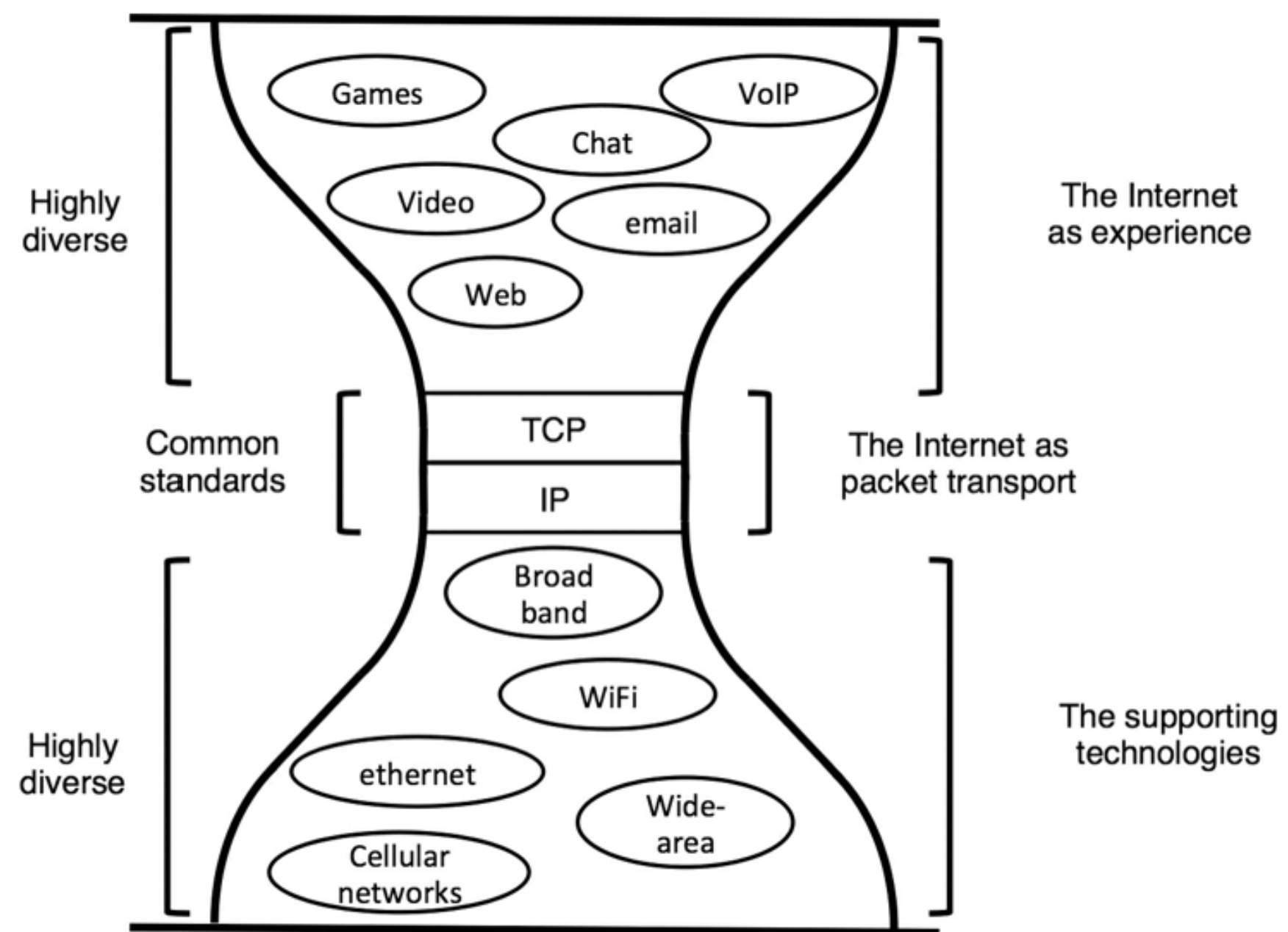



**“One does not watch a masquerade performance from one vantage point.”**

**- Okwui Enwezor**



## Solution



a well-provisioned network measurement and systems research test-bed designed to support:

- Internet measurement,
- Protocol design,
- Distributed systems research, and
- Collaborative computing in Africa

## Goals

1. Visibility
2. Topology-aware
3. End-to-End
4. Collaborative
5. Neutral
6. Multi-tenant and Multi-homed



# Big Idea: An AS and CDN for Research

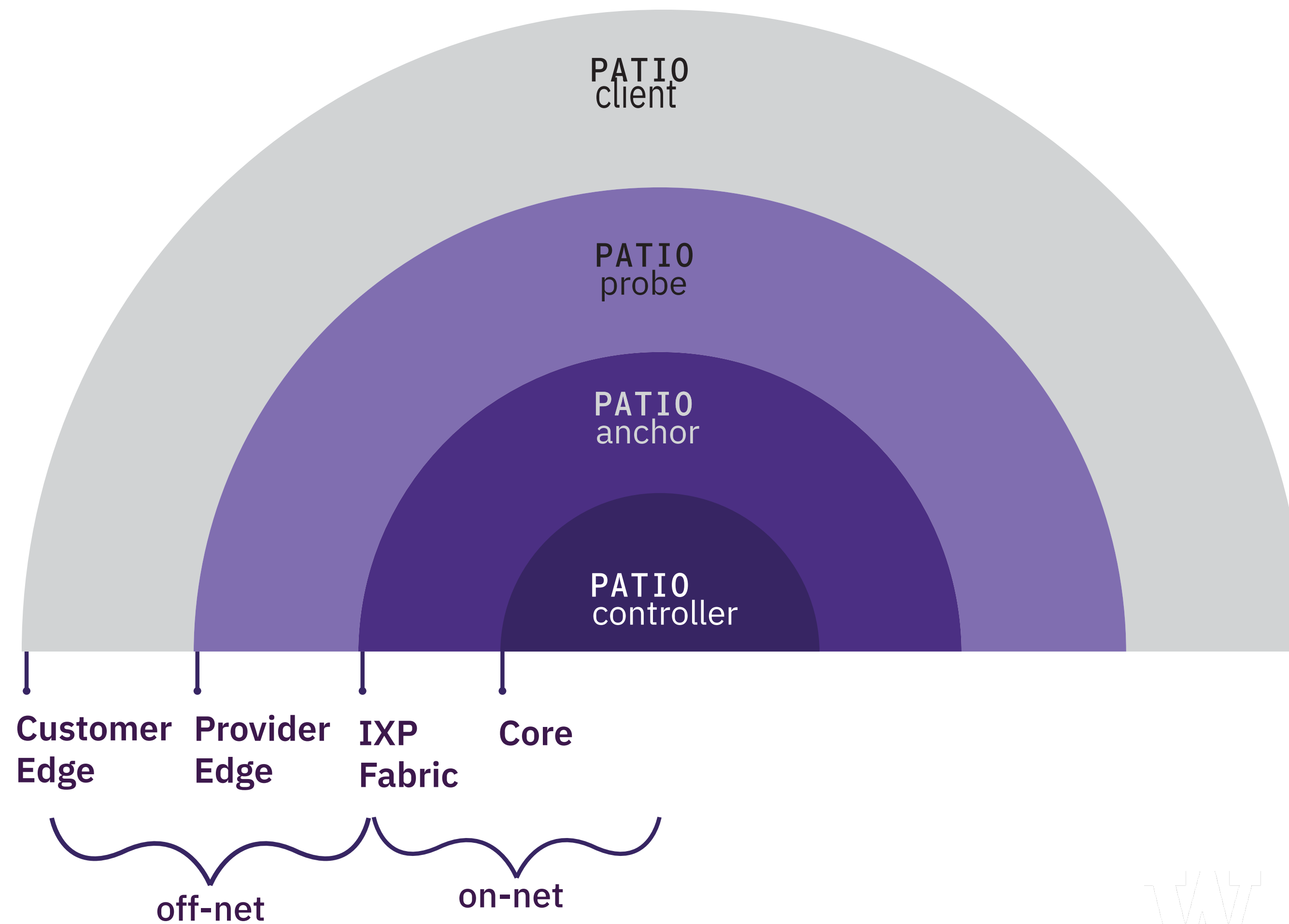



# Architecture: A Research Autonomous System and Content Delivery Network

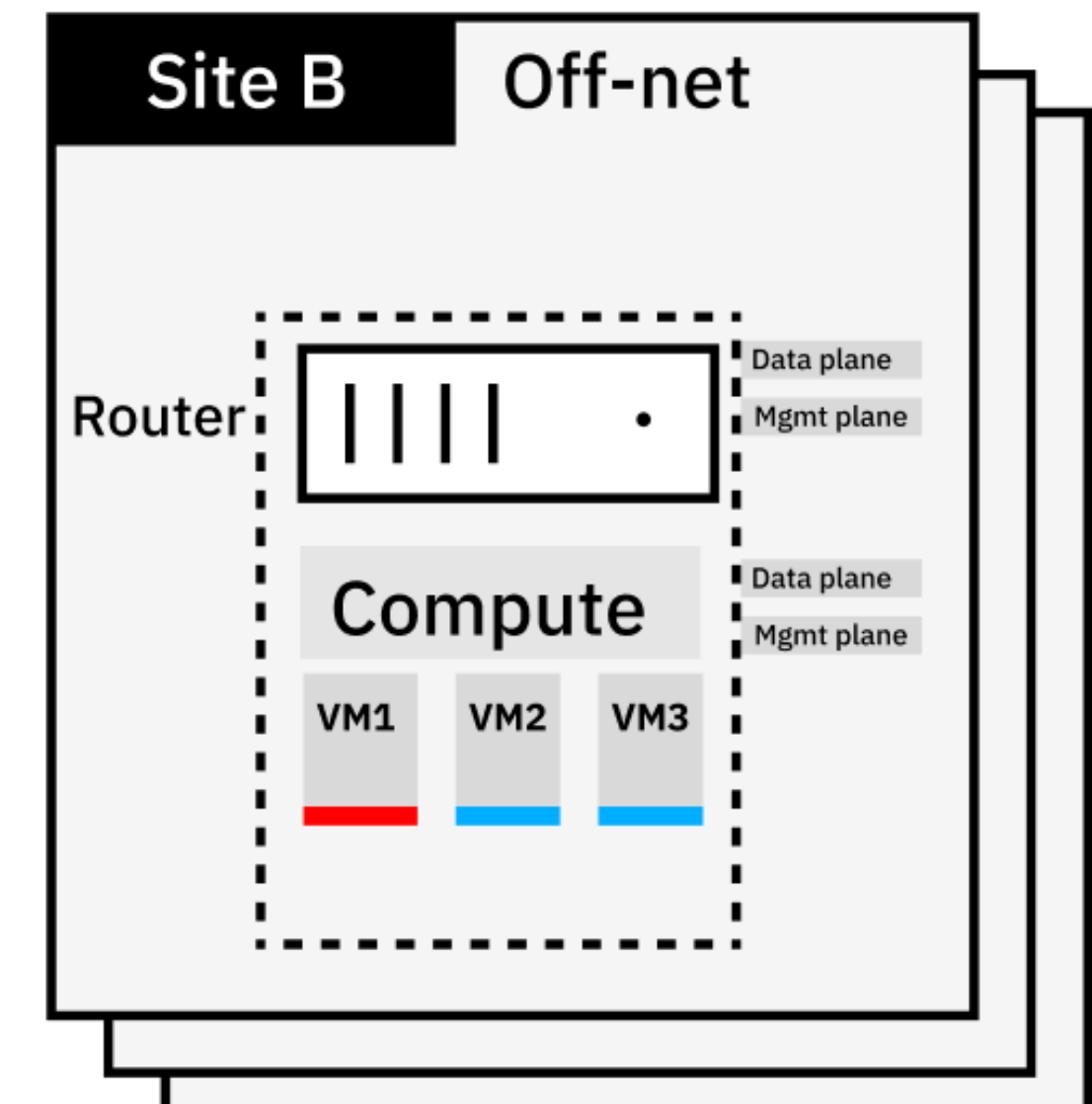
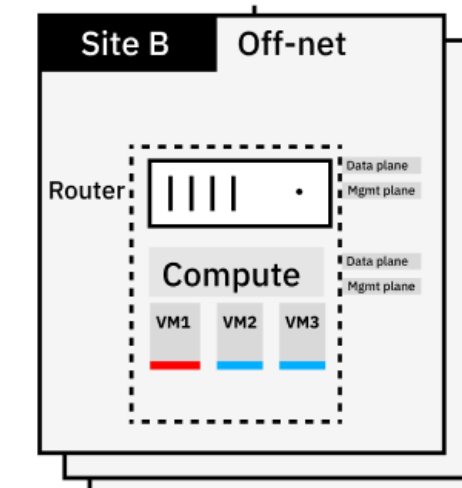
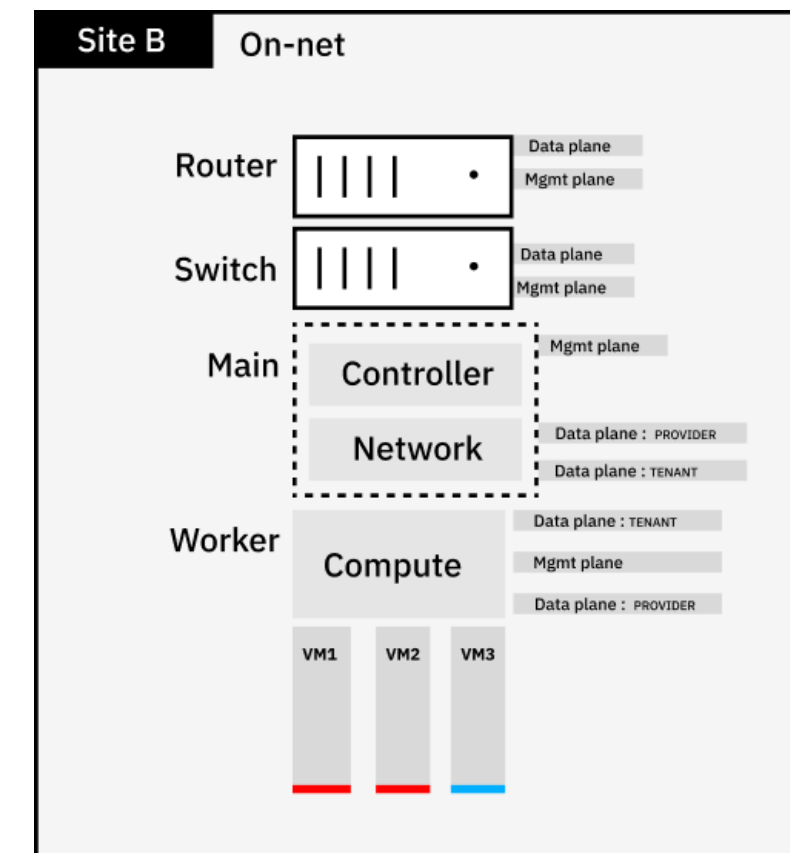
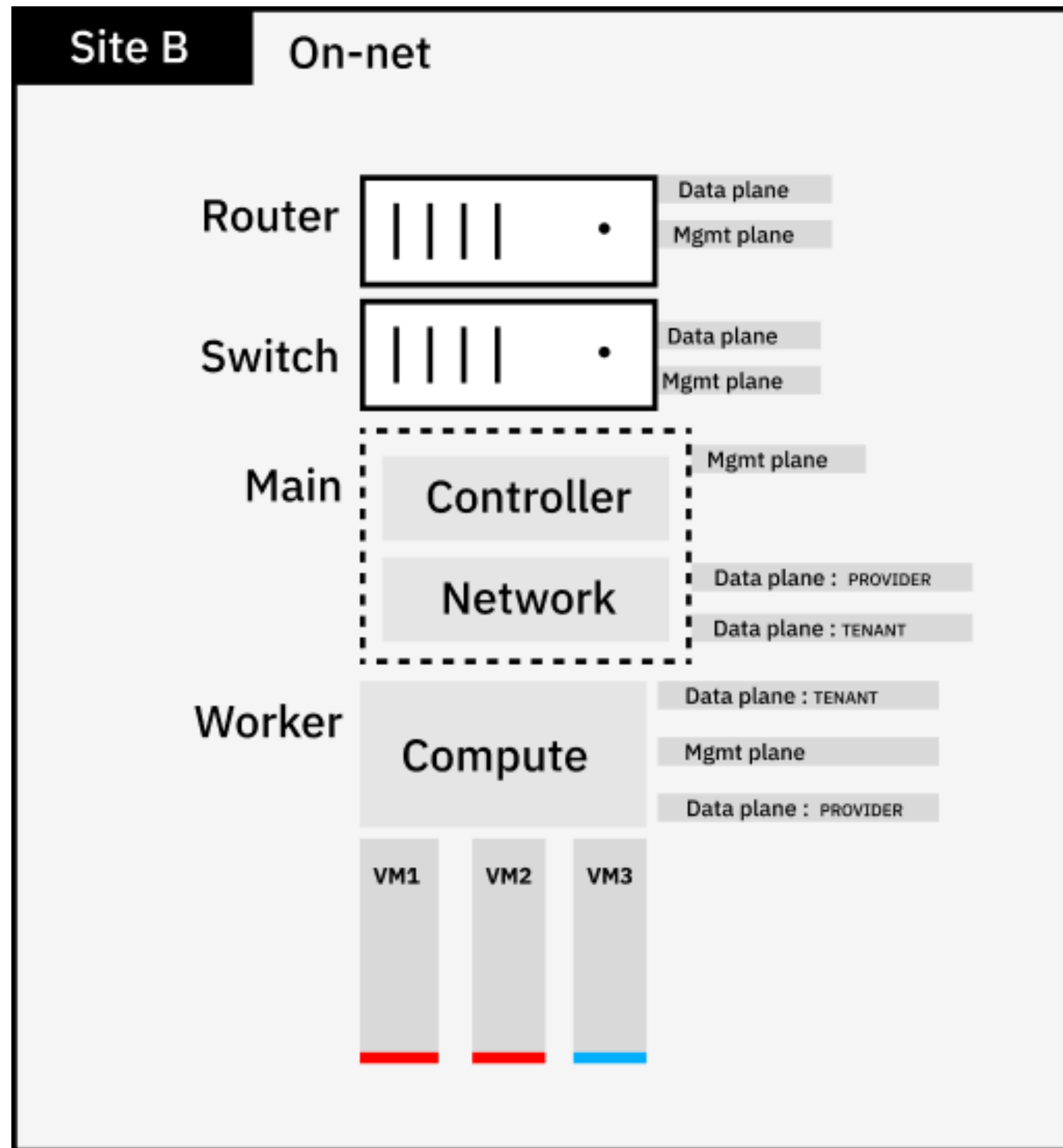



# Architecture: A Research Autonomous System and Content Delivery Network

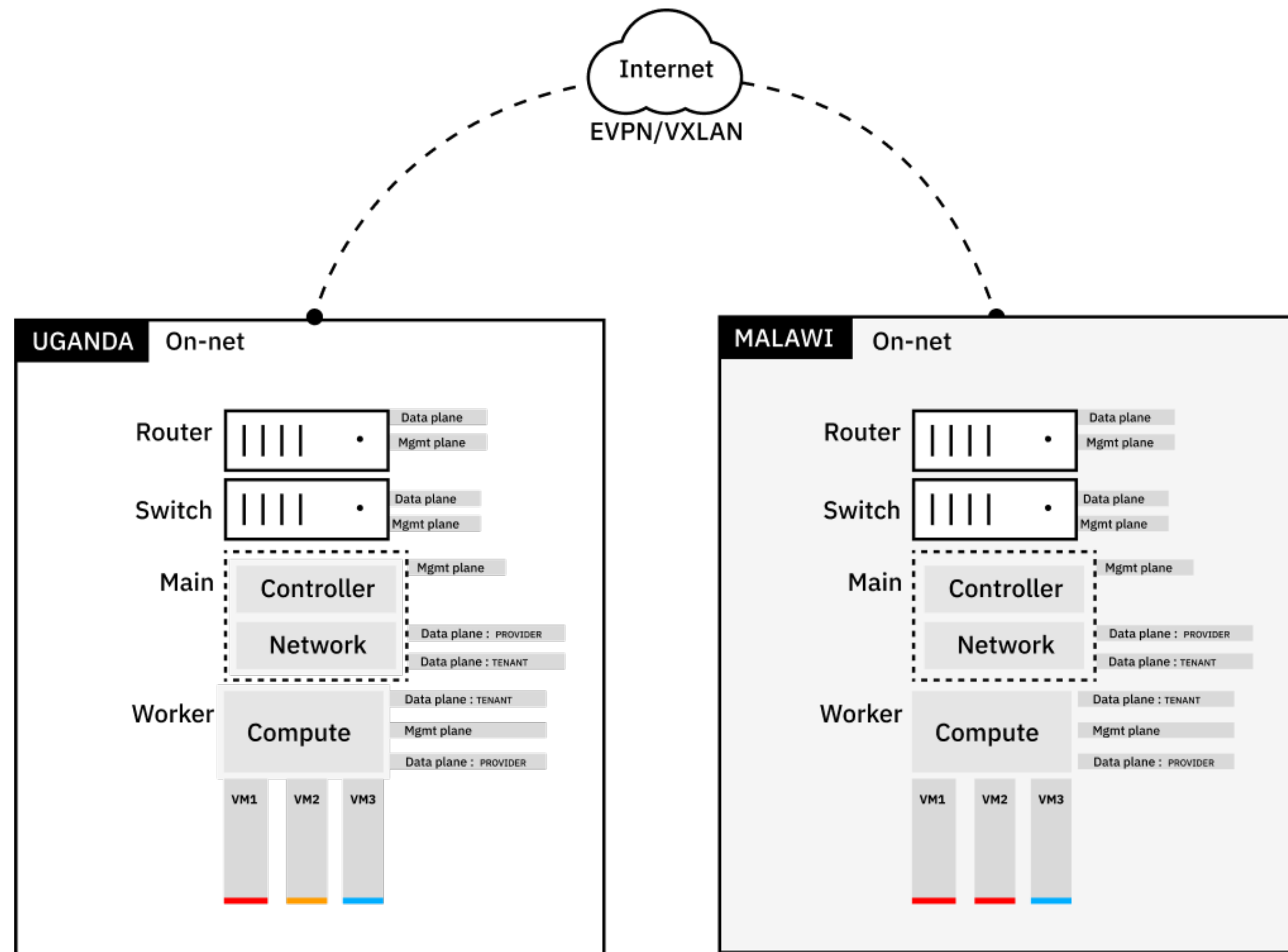

# Existing Models

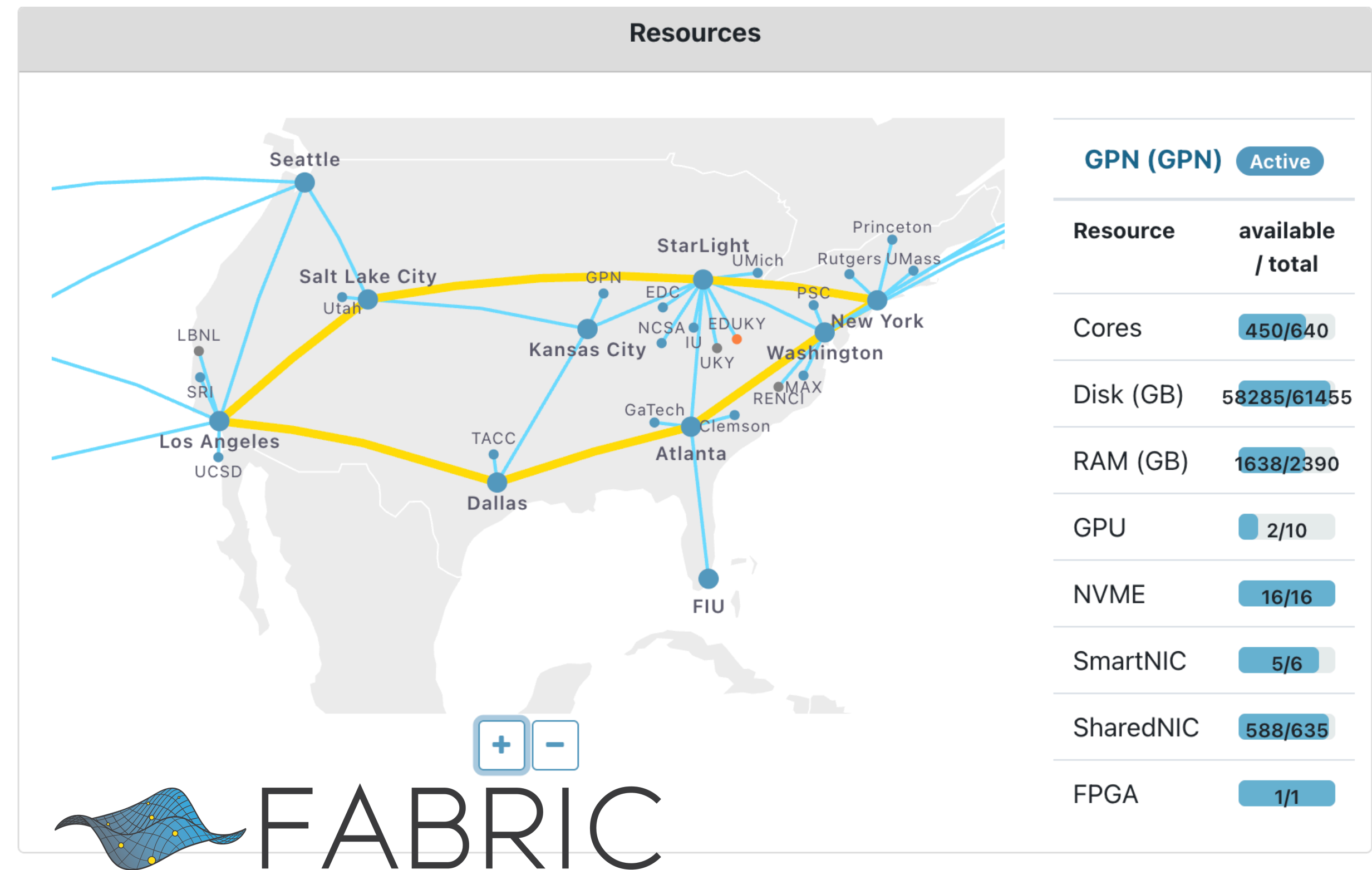



# Partners and Supporters

## NRENS



## Funder



## IXPs



## Providers





**Interested?**



Check us out at [patio.cs.washington.edu](http://patio.cs.washington.edu)!

**Innocent Obi Jr**  
[innoobi@cs.washington.edu](mailto:innoobi@cs.washington.edu)